



Soft&Go

PLUS

Single flavor counter top machine to produce soft gelato, yogurt, ice cream and other frozen desserts.

Unique Front loading refrigerated cabinet Equipped with a peristaltic pump for simple operation and smooth creamy high quality product production

A compact machine

Perfect for all shops that have limited space. Even in restaurants and in coffee shops it is now possible to taste a delicious gelato and frozen yogurt

Efficient

It produces excellent cream gelatos and fruit sorbets together with a very good frozen yogurt

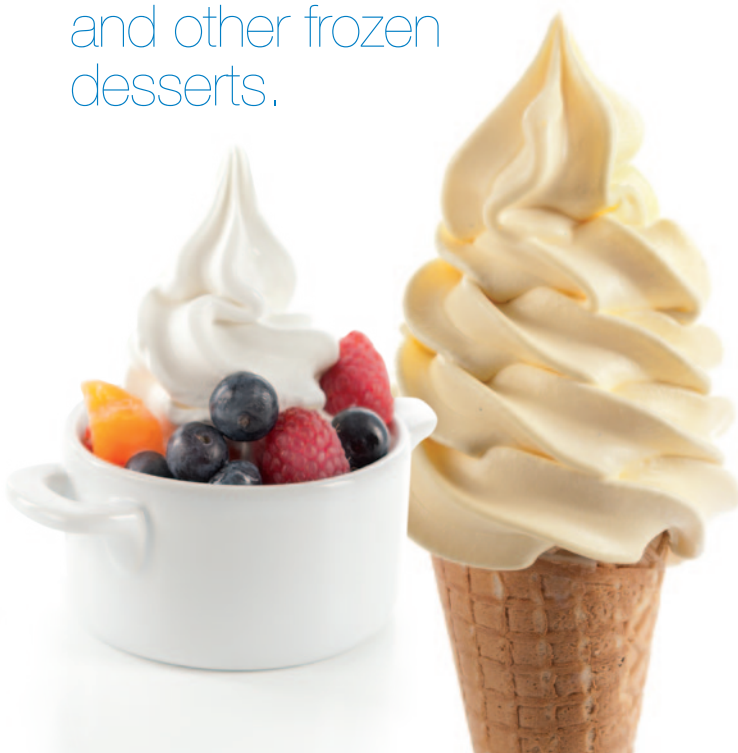

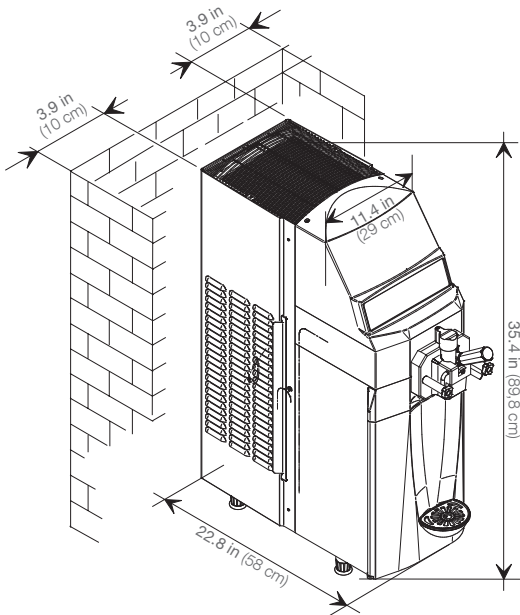

Optional configurations



Teorema Remote Control

Provides an e-maintenance service that lets you manage your equipment more efficiently with Real-Time Remote & in-Store: Product Quality adjustments, Clean Cycle Indication, Volumes and Remote Diagnostics



Single portions dispensing head

With interchangeable nozzles to make single portions and delights



Self closing Handle

The dispenser closes automatically stopping the flow of ice cream, eliminating any waste and preventing a mess

	Flavours	Pump	Hourly production <small>(2.6 oz-75gr portions)</small>	Tank Capacity <small>qts (Liters)</small>	Minumun Circuit Ampacity <small>Amps</small>	Max fuse size <small>Amps</small>	Power Supply <small>V / Hz / ph</small>	Cooling System	Refrigerant	Net Weight <small>lb (kg)</small>
Soft&Go PLUS	1	Peristaltic	180*	5.4 (5)	tbd**	tbd**	208-230/60/1	Air	R404	194 (88)

* production capacity depends on the mix used and the room temperature

** pending approval

Features

Benefits

Flexible Mix Delivery System	Refrigerated holding cabinet capable of pumping directly from Bags "BIB" or stainless steel 5.4 quart mix container
Multi-functional LED Display Panel	Soft & go will inform you about: mix temperature, consistency, status of the product and status of the mix in the hopper
Visual alarm	Alarms for low mix level, improper loading, cabinet door open, cabinet defrost needed, machine cleaning, etc.
Front loading refrigerated Cabinet	Automatic defrost system, frost ventilated and cooled
Air cooled	Vertical ventilation with side intake and top air discharge
Front mix filling	Very easy mix filling directly from the front of the machine. All you need to do is open the mix container/bag and pour into the container provided or simply connect to the BIB
Defrost system	Cylinder defrost mode will heat the cylinder and simplify the cleaning procedure
Overrun adjustment directly from the display	It allows the operator to modify the overrun in a very easy way, directly from the front control panel display with no need to purchase or change parts