

ROTISSERIE

CHICKEN



ROTISSERIE

Model | PR-60

WHY SHOULD YOU USE THE ROTISSERIE ?

UNSURPASSED QUALITY ROASTING

The rotation is calculated so that the juice drips from one skewer to the next skewer directly below it. This method of dripping from one skewer to the next prevents shrinkage and at the same time enhances the taste and color of meat.

MODULATING BURNER

We use a modulating burner to maintain consistent heat. The flame never goes out, it is increased or decreased depending on user demands. Direct heat is kept at a proper distance in order to prevent toughening of meat.

UNIQUE ROTATION SYSTEM

A vertical rotation cycle (up and down) awaits the chickens, once inside the cooking chamber, to ensure an even cooking. The second rotation cycle is carefully calculated so that every drop of juice from one skewer falls on the one directly below it.

EYE CATCHING DISPLAY

Two wide-open toughened glass doors for easy access and optimizing visibility of production, hence stimulating consumer's impulsive buying.

EASE OF USE

Large doors give access to the vast interior, and the way that the skewers are fixed makes loading and unloading easy.



BASIC FEATURES

- Single gas connection
- Interior and exterior stainless steel walls and floor
- Tempered glass door with stainless steel frame
- Vertical rotation system (Up and down)
- 12 stainless steel skewers
- Digital controls
- Doors on each side for easy maintenance and access to mechanical systems and electrical components
- Adjustable wheels with locking mechanism
- Bottom water pan with auto fill
- Skewer rotation knee-kick Start / Stop mechanism

OPTIONAL FEATURES

- In-cabinet lighting

INSTALLATION

This equipment is delivered fully assembled and ready to be used. It can easily pass through a standard door of 36" x 80".

All electrical, gas, water and chimney hook-ups, as well as the rotisserie burner start-up, are at the customer's expense and must be performed by a qualified technician and according to local code. Each oven must be hooked-up to a hood pressure switch supplied and installed at the customer's expense.

ROTISSERIE

Model | PR-60

CLEARANCE REQUIRED

Floor to ceiling	91"
Side and back to wall	2"
Floor	Approved for combustible surfaces

For your safety, our ROTISSERIE oven meets ETL Certification for the United States and Canada. Certified to CSA STD.1.8.2002. Conform to ANSI STD.Z 83.11.2002

HOOK-UP FEATURE

Model	Inlet gas pipe size	Gas power (BTU / HR)	Manifold gas pressure (water column)	Inlet pressure (W.C.)	Electricity
PR-60	3/4" NPT	85 000	0" W.C.	5"-14"	110V / 1PH / 60 Hz / 10A

GENERAL INFORMATION

Model	Width	Poultry capacity (3 1/2 lb / each)	# of skewers	Temperature limit	Distance between skewers	Delivery weight
PR-60	64 1/8"	60	12	450 °F	7 1/2"	1,600 lb



MACHINE DIMENSIONS

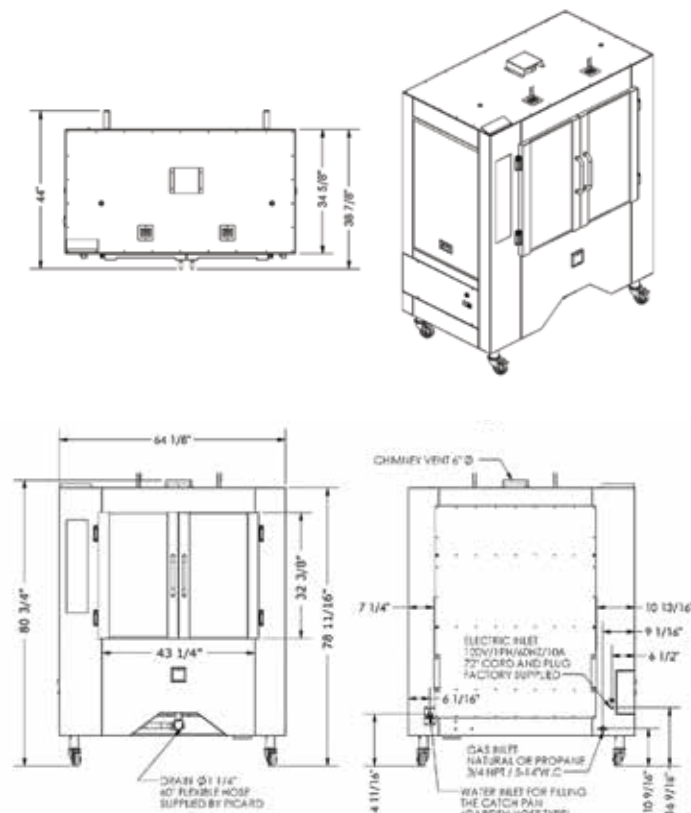

Technical Data	Model PRD-12-60
Cooking type	Continuous
Heating	Natural gas or propane gas
Supply voltage	120
Phase - Frequency (special voltage available)	Single - 60HZ
Lights - Wattage Each - Total Lightning Wattage	1 - 100 - 100
# Motors - Motor Hp - RPM - Full Load Amps Each	1 - 1/3 - 1725 - 7
Amperage - 1 PH @ 208V - 220V - 240V	Special Order
Amperage @ 120V	10
Frequence 50HZ	Special Order
BTU's Natural - Propane	135,000
Vent opening	6" diameter
Nominal gas pressure natural - Propane	3 1/2 - 11
Gas connection (male end required)	3/4" NPT
Net weight / Shipping weight	1,600 lb
Dimensions : height	75 5/16"
Depth (without doors)	32 7/8"
Depth (with doors)	36 7/8"
Width	65 3/4"
Spit - spit lenght - distance between spits	12 - 40" - 7 1/2"
Chicken capacity 3 1/3 lb each	60
Tempered glass doors 1/4" x 19 5/8" x 36 1/4"	2

* Continuous product development is a policy at Picard. Therefore, we reserved the right to modify these features and/or the design without prior notification.

** The Rotisserie Oven is delivered fully assembled. This oven must be vented using an appropriate hood.